



International  
Civil Aviation  
Organization

Organisation  
de l'aviation civile  
internationale

Organización  
de Aviación Civil  
Internacional

Международная  
организация  
гражданской  
авиации

منظمة الطيران  
المدني الدولي

国际民用  
航空组织

Tel.: +1 514-954-8219 ext. 6710

9 August 2018

Ref.: AN 13/2.1-18/67

**Subject:** Approval of Amendment 8 to the PANS-ATM

**Action required:** a) Implementation of the amendment on 8 November 2018; and b) Publication of any differences as of 8 November 2018

Sir/Madam,

1. I have the honour to inform you that the Air Navigation Commission, acting under delegated authority, on 26 June 2018, approved Amendment 8 to the fifteenth edition of the *Procedures for Air Navigation Services — Air Traffic Management* (PANS-ATM, Doc 4444), for applicability on 8 November 2018. The amendment was approved on 6 August 2018 by the President of the Council on behalf of the Council in accordance with established procedure. Copies of the amendment are available as attachments to the electronic version of this State letter on the ICAO-NET (<http://portal.icao.int>) where you can access all other relevant documentation.

2. Amendment 8 stems from proposals developed by the first meeting of the Separation and Airspace Safety Panel (SASP/1), the fourth meeting of the Air Traffic Management Operations Panel (ATMOPSP/4), the thirteenth meeting of the Instrument Flight Procedure Panel (IFPP/13) and third meeting of the Flight Operations Panel (FLTOPSP/3), the twelfth meeting of the Aeronautical Information Service (AIS) to Aeronautical Information Management (AIM) Study Group (AIS-AIMSG/12) and the second meeting of the Meteorology Panel (METP/2). The amendment is related to:

- a) lateral separation and parallel operations;
- b) remote ATS and ATM procedures;
- c) the restructure of PANS-OPS, Volume I, Parts I and II (Phase II);
- d) the restructure of Annex 15 and introduction of a new PANS-AIM; and
- e) the transmission of space weather information as part of a flight information service.

3. An implementation task list, including an outline of guidance material, and an impact assessment for the amendment are presented in Attachments B and C, respectively.

4. Your Government is invited by the Council to implement the provisions of the PANS-ATM as amended. In this connection, I draw your attention to the decision taken by the Council, on 1 October 1973, to discontinue the publication of differences in Supplements to the PANS documents and, instead, to request States to publish up-to-date lists of significant differences from PANS documents in their Aeronautical Information Publications (AIPs).

5. May I, therefore, invite your Government to publish in your Aeronautical Information Publication a list of any significant differences which will exist on 8 November 2018 between the amended provisions of the PANS-ATM and your national regulations and practices.

Accept, Sir/Madam, the assurances of my highest consideration.

Fang Liu  
Secretary General

**Enclosures:**

- A — Amendment to the Foreword of the PANS-ATM
- B — Implementation task list and outline of guidance material in relation to Amendment 8 to the PANS-ATM
- C — Impact assessment in relation to Amendment 8 to the PANS-ATM

**ATTACHMENT A** to State letter AN 13/2.1-18/67

**AMENDMENT TO THE FOREWORD OF THE  
PANS-ATM (DOC 4444), FIFTEENTH EDITION**

Add the following element at the end of Table A:

<i>Amendment</i>	<i>Source(s)</i>	<i>Subject</i>	<i>Approved Applicable</i>
8	The first meeting of the Separation and Airspace Safety Panel (SASP/1), the fourth meeting of the Air Traffic Management Operation Panel (ATMOPSP/4) and the Secretariat, the third meeting of the Flight Operations Panel (FLTOSP/3), the thirteenth meeting of the Instrument Flight Procedure Panel (IFPP/13), the twelfth meeting of the Aeronautical Information Service (AIS) to Aeronautical Information Management (AIM) Study Group (AIS-AIMSG/12) and the second meeting of the Meteorology Panel (METP/2).	Lateral separation and parallel operations, remote ATS and ATM procedures, the restructure of PANS-OPS, Volume I, Parts I and II (Phase II), the restructure of Annex 15 and incorporation of AIM concepts, the transmission of space weather information as part of a flight information service.	6 August 2018 8 November 2018

-----



**IMPLEMENTATION TASK LIST AND OUTLINE OF GUIDANCE MATERIAL IN RELATION TO AMENDMENT 8 TO THE PANS-ATM (DOC 4444)**

**1. IMPLEMENTATION TASK LIST**

1.1 Essential steps to be followed by a State in order to implement Amendment 8 to the PANS-ATM:

- a) conduct a gap analysis between the amendment and national regulatory framework;
- b) identification of the rule-making process necessary to transpose the amendment concerning the following subjects into the national requirements, where necessary;
- c) drafting of the modification to the national requirements and means of compliance;
- d) official adoption of the national requirements and means of compliance;
- e) identification and publication of significant differences, if any, in the State's aeronautical information publication (AIP);
- f) modification of surveillance programmes to include new requirements, if applicable;
- g) revision of guidance material and checklists for safety oversight inspectors;
- h) training of inspectors based on the revised inspector guidance material; and
- i) ensure compliance by industry (air navigation service provider (ANSP) and operator) through safety oversight activities.

**2. STANDARDIZATION PROCESS**

2.1 Approval date: 6 August 2018

2.2 Applicability date: 8 November 2018.

2.3 Embedded applicability date(s): N/A.

## 3. SUPPORTING DOCUMENTATION

## 3.1 ICAO documentation

<b>Title</b>	<b>Type (PANS/TI/Manual/Circ)</b>	<b>Planned publication date</b>
<i>Procedures for Air Navigation Services — Aeronautical Information Management (PANS-AIM, Doc 10066)</i>	PANS	November 2018
<i>Aeronautical Information Services Manual (Doc 8126)</i>	Manual (update)	2018
<i>Performance-based Navigation (PBN) Manual (Doc 9613)</i>	Manual	Available
<i>Simultaneous Operations on Parallel or Near-Parallel Instrument Runways (Doc 9643)</i>	Manual (new edition)	2018
<i>Use of Performance-based Navigation (PBN) in Airspace Design (Doc 9992)</i>	Manual	2018
<i>Guidelines for the Implementation of Lateral Separation Minima Circular (Cir 341-AN/184)</i>	Circular	Available
<i>Guidelines for the Implementation of Reduced Divergence Departures (Circ 350)</i>	Circular	2018
<i>Manual on Space Weather Information in Support of International Air Navigation (Doc 10100)</i>	Manual	2018

## 3.2 External documentation

<b>Title</b>	<b>External Organization</b>	<b>Publication date</b>
Annex to European Aviation Safety Agency (EASA) Executive Director Decision 2015/014/R	European Aviation Safety Agency (EASA)	3 July 2015

## 4. IMPLEMENTATION ASSISTANCE TASKS

<b>Type</b>	<b>Global</b>	<b>Regional</b>
Regional workshop as resources permit		ICAO regional offices or States offering to host regional events

5. **UNIVERSAL SAFETY OVERSIGHT AUDIT PROGRAMME (USOAP)**

5.1 No major changes to the USOAP CMA protocol questions are envisaged. However, in the area of air navigation service, existing protocol questions may need amendment or new protocol questions may be required to assess effective implementation by States. This will be assessed during the next amendment cycle of the protocol questions.

-----





## ATTACHMENT C

### IMPACT ASSESSMENT IN RELATION TO AMENDMENT 8 TO THE PANS-ATM (DOC 4444)

#### 1. INTRODUCTION

1.1 Amendment 8 to the PANS-ATM is intended to address the requirements and procedures for the following:

- Lateral separations and parallel operations
- Remote ATS and ATM procedures
- Restructure of PANS-OPS, Volume I, Parts I and II (phase II)
- Restructure of Annex 15, incorporation of AIM concepts
- Transmission of space weather information as part of a flight information service

#### 2. IMPACT ASSESSMENT

##### *Lateral separation*

2.1 *Safety impact:* Positive — The increased awareness of the impact of aircraft turn performance on lateral separation is expected to provide a consequential improvement of safety in airspaces where small separation minima and route spacing are being (or have been) implemented. The reduction of separation minima, will bring with it a consequent increase in the availability of clearances to achieve optimal flight levels. At times this will mean facilitation of level changes for weather avoidance and other such hazards.

2.2 *Financial impact:* Positive — Reductions in separation, with consequent increased availability of clearances to achieve optimal flight levels will result in decrease in fuel cost.

2.3 *Security impact:* Negligible/None — None of these proposals are related to security.

2.4 *Environmental impact:* Positive — Reductions in separation, with consequent increased availability of clearances to achieve optimal flight levels will result in an overall reduction of emissions.

2.5 *Efficiency impact:* Positive — Increased availability of clearances to achieve optimal flight levels will result in an overall increase in efficiency, with a resultant decrease in fuel cost.

2.6 *Expected implementation time:* 1 to 2 years — State implementation is dependent on their process for regulation amendment. As for the industry, it will take very little time, as this is related to

increasing the necessary awareness of the effect of turn types on lateral separation and consequently, when a controller needs to build in an alternative separation.

### ***Parallel operations***

2.7 *Safety impact:* Positive — This amendment is expected to result in improved safety through the use of new technologies for the provision of precision departures and precision approaches associated with parallel runway operations. Additionally, the use of new performance-based navigation (PBN) departure and approach procedures will take advantage of the inherent safety aspects of these types of procedures, particularly with regards to improved track keeping performance, tight lateral accuracy and repeatability.

2.8 *Financial impact:* Positive — The gains made by utilizing the required navigation performance (RNP) procedures in parallel operations will improve efficiency and will result in reduced delays and an increase in efficient airspace use, with a consequential decrease in fuel cost.

2.9 *Security impact:* Negligible/None — None of these proposals are related to security.

2.10 *Environmental impact:* Positive — The gains made by utilizing the RNP procedures in parallel operations will improve efficiency and will result in reduced delays and an increase in efficient airspace use, with a consequential reduction in fuel burn and emissions.

2.11 The parallel approach procedures will result in shortened downwind legs and consistently flown base turns, hence more efficient positioning of aircraft on final approach to parallel runways during simultaneous operations. Noise restrictions could also be more effectively resolved, given the ability to provide a range of flexible PBN-designed approach procedures, and utilizing consistent and highly repeatable turn performance enabled by radius-to-fix (RF) functionality, thus minimizing the noise exposure for specific areas under traditional approach paths.

2.12 *Efficiency impact:* Positive — As discussed above, greater efficiencies will be provided through the new procedures and/or technologies identified through potentially reduced track miles for approaches: higher utilization of aircraft avionics and automation combined with PBN specifications will provide increased flexibility to enhanced aircraft arrivals and precision approach guidance.

2.13 *Expected implementation time:* 1 to 2 years — State implementation is dependent on their process for regulation amendment. As for the industry, implementation will take very little time, as this is related to increasing the necessary awareness of the effect of turn types on lateral separation and consequently, when a controller needs to build in an alternative separation.

### ***Remote ATS and ATM procedures***

2.14 *Safety impact:* Positive — The new procedure will facilitate the use of remote air traffic services technology in the provision of aerodrome control service and will facilitate the provision of oversight in the case of remote control. The amendments maintain PANS-ATM references current against new publications and align Annex 14 — *Aerodromes* and PANS-ATM. They also strengthen the provisions related to the specification of the limit of a vector and will guarantee that due consideration is given to specifying the limit of a vector when it is needed. This will strengthen the requirement in locations where it needs to be applied and alleviate it in locations where its application is not warranted. The amendments will also reduce the risk of confusion caused by the difference in phraseologies between tow tractors and other vehicles in the aerodrome/

2.15 *Financial impact:* Negligible/None — For States, the improvement of existing operational procedures requires minimal State administrative activity and does not entail any specific training. The actual financial cost is expected to be negligible as covered by the normal cost of procedure maintenance. For the industry, the amendment improves efficiency in the application of procedures. Its implementation is not foreseen to generate extra cost.

2.16 *Security impact:* Negligible/None — No impact.

2.17 *Environmental impact:* Negligible/None — No impact.

2.18 *Efficiency impact:* Positive — The amendment provides the flexibility to ensure that the limit of a vector is stated when needed and omitted when not. This limits frequency congestion and will ensure a uniform application of the procedure. The amendment related to remote ATS allows the provision of ATS services in locations where it would not otherwise be provided and adapts the regulatory framework to emerging technologies.

2.19 *Expected implementation time:* 0 to 1 year — The regulations to be adapted are mostly operational procedures. Their amendment is not foreseen to generate undue delays.

***Consequential amendment to PANS-ATM due to the restructure of PANS-OPS, Volume I, Parts I and II (Phase II)***

2.20 *Safety impact:* Positive — Improved clarity and the addition of requirements for PBN procedures will improve the standardized implementation of PBN.

2.21 *Financial impact:* Negligible/None

2.22 *Security impact:* Negligible/None.

2.23 *Environmental impact:* Negligible/None.

2.24 *Efficiency impact:* Negligible/None.

2.25 *Expected implementation time:* 0 to 1 year.

***Consequential amendment as a result of the restructure of Annex 15 and introduction of a new PANS-AIM.***

2.26 *Safety impact:* Positive — The proposed amendment ensures alignment among requirements, as contained in Annex 15, the PANS-AIM (Doc 10066) and the PANS-ATM (Doc 444) and avoids misinterpretation. Therefore there is an indirect benefit in terms of safety.

2.27 *Financial impact:* Negligible — The proposed amendment only modifies a reference in the PANS-ATM and therefore the impact on States and Industry is considered negligible.

2.28 *Security impact:* Negligible/None. — No security impact is expected with this proposal.

2.29 *Environmental impact:* Negligible/None — No environmental impact is expected with this proposal.

2.30 *Efficiency impact:* Positive — The proposed amendment provides a positive efficiency impact and ensures alignment among requirements, as contained in Annex 15 — *Aeronautical Information Services*, the *Procedures for Air Navigation Services - Aeronautical Information Management* (PANS-AIM, Doc 10066) and the PANS-ATM. Requirements are retrieved in a more efficient way as they are cross-referenced. The change is, therefore, considered beneficial

2.31 *Expected implementation time:* Less than one year.

***Transmission of space weather information as part of a flight information service***

2.32 *Safety impact:* Positive — The safety of aircraft operations is enhanced with access to improved information on current and expected atmospheric conditions. Improved information about space weather events that may affect communications, navigation and surveillance systems utilized by the aviation industry will lead to improved decision-making, particularly in the planning phase, to mitigate the potential impacts of space weather events on aircraft operations.

2.33 *Financial impact:* Negligible — The cost impact for States and industry is considered neutral, as ANSPs are currently required to provide meteorological information.

2.34 *Security impact:* Negligible/None — Data security and governance may be enhanced with the implementation of the ICAO Meteorological Information Exchange Model (IWXXM) in a system wide information management (SWIM) environment.

2.35 *Environmental impact:* None.

2.36 *Efficiency impact:* Positive — The efficiency of aircraft operations is enhanced with more timely access to and incorporation of digital meteorological information in flight planning, flow management and aircraft management. Improved information about space weather events will improve route selection and fuel-loading decisions and minimize the need for rerouting flights due to the potential impacts of space weather events.

2.37 *Expected implementation time:* 1 to 2 years — This timeline refers to space weather information system operations under regulatory and co-operative frameworks. Training will only need to cover the representation of existing expertise in new templates and communications protocols.

**AMENDMENT No. 8**

**TO THE**

**PROCEDURES  
FOR  
AIR NAVIGATION SERVICES**

**AIR TRAFFIC MANAGEMENT**

**(Doc 4444)**

**INTERIM EDITION**

The text of Amendment No. 8 to the PANS-ATM (Doc 4444) was approved by the President of the Council of ICAO on behalf of the Council on **6 August 2018** for applicability on **8 November 2018**. This interim edition is distributed to facilitate implementation of the amendment by States. Replacement pages incorporating Amendment No. 8 are expected to be distributed in October 2018. (State letter AN 13/2.1-18/67 refers.)

**August 2018**

**INTERNATIONAL CIVIL AVIATION ORGANIZATION**



**NOTES ON THE EDITORIAL PRESENTATION  
OF THE AMENDMENT 8 TO THE PANS-ATM**

The text of the amendment is arranged to show deleted text with a line through it and new text highlighted with grey shading, as shown below:

- |   |                                   |
|---|-----------------------------------|
| 1. <del>Text to be deleted is shown with a line through it.</del>   | text to be deleted                |
| 2. <u>New text to be inserted is highlighted with grey shading.</u>   | new text to be inserted           |
| 3. <del>Text to be deleted is shown with a line through it</del><br><u>followed by the replacement text which is highlighted</u><br><u>with grey shading.</u> | new text to replace existing text |

**TEXT OF AMENDMENT 8 TO THE  
PROCEDURES FOR AIR NAVIGATION SERVICES  
AIR TRAFFIC MANAGEMENT  
(PANS-ATM, DOC 4444)**

**Chapter 1**

**DEFINITIONS**

...

***Dependent parallel approaches.*** Simultaneous approaches to parallel or near-parallel instrument runways where ~~radar~~ **ATM surveillance system** separation minima between aircraft on adjacent extended runway centre lines are prescribed.

...

***Independent parallel approaches.*** Simultaneous approaches to parallel or near-parallel instrument runways where ~~radar~~ **ATM surveillance system** separation minima between aircraft on adjacent extended runway centre lines are not prescribed.

...

***Instrument approach procedure (IAP).*** A series of predetermined manoeuvres by reference to flight instruments with specified protection from obstacles from the initial approach fix, or where applicable, from the beginning of a defined arrival route to a point from which a landing can be completed and thereafter, if a landing is not completed, to a position at which holding or en-route obstacle clearance criteria apply. Instrument approach procedures are classified as follows:

*Non-precision approach (NPA) procedure.* An instrument approach procedure designed for 2D instrument approach operations Type A.

*Note.— Non-precision approach procedures may be flown using a continuous descent final approach (CDFA) technique. CDFAs with advisory VNAV guidance calculated by on-board equipment (see PANS-OPS (Doc 8168), Volume I, Part I, Section 4, Chapter 1, paragraph 1.8.1) are considered 3D instrument approach operations. CDFAs with manual calculation of the required rate of descent are considered 2D instrument approach operations. For more information on CDFAs, refer to PANS-OPS (Doc 8168) Volume I, Part II, Section 54, Chapter 1, paragraphs 1.7 and 1.8.*

...

***Normal operating zone (NOZ).*** ~~Airspace of defined dimensions extending to either side of an **HLS** localizer published instrument approach procedure final approach course, and/or **MLS final approach** or track. Only ~~the inner~~ that half of the normal operating zone adjacent to a no transgression zone (NTZ) is taken into account in independent parallel approaches.~~



...

**Visual surveillance system.** An electro-optical system providing an electronic visual presentation of traffic and any other information necessary to maintain situational awareness at an aerodrome and its vicinity.

...

## Chapter 4

### GENERAL PROVISIONS FOR AIR TRAFFIC SERVICES

...

#### 4.9 WAKE TURBULENCE CATEGORIES

...

##### 4.9.1 Wake turbulence categories of aircraft

...

*Note 1.— Helicopters produce vortices when in flight and there is some evidence that, per kilogram of gross mass, their vortices are more intense than those of fixed-wing aircraft. When hovering in ground effect or air taxiing, helicopters generate downwash producing high velocity outwash vortices to a distance approximately three times the diameter of the rotor.*

...

## Chapter 5

### SEPARATION METHODS AND MINIMA

...

#### 5.4.1 Lateral separation

##### 5.4.1.1 LATERAL SEPARATION APPLICATION

5.4.1.1.1 Lateral separation shall be applied so that the distance between those portions of the intended routes for which the aircraft are to be laterally separated is never less than an established distance to account for navigational inaccuracies plus a specified buffer. This buffer shall be determined by the appropriate authority and included in the lateral separation minima as an integral part thereof.

*Note.— In the minima specified in 5.4.1.2 an appropriate buffer has already been included.*

5.4.1.1.2 Lateral separation of aircraft is obtained by requiring operation on different routes or in different geographical locations as determined by visual observation, by the use of navigation aids or by the use of area navigation (RNAV) equipment.

5.4.1.1.3 When information is received indicating navigation equipment failure or deterioration below the navigation performance requirements, ATC shall then, as required, apply alternative separation methods or minima.

5.4.1.1.4 ~~When an aircraft turns onto an ATS route via a flyover waypoint, a separation other than the normally prescribed lateral separation shall be applied for that portion of the flight between the flyover waypoint where the turn is executed and the next waypoint.~~ Where a route flown by an aircraft involves a specified turn which will result in the minimum lateral separation being infringed, another type of separation or another minimum shall be established prior to the aircraft commencing the turn. (see Figures 5-1 and 5-2).

*Note 1.— For flyover waypoints aircraft are required to first fly over the waypoint before executing the turn. After the turn the aircraft may either navigate to join the route immediately after the turn or navigate to the next defined waypoint before re-joining the route. This will require additional lateral separation on the overflown side of the turn (refer to Figure 5-1).*

*Note 2.— ~~This does not apply to ATS routes that have turns using fly-by waypoints.~~ An aircraft may commence a fly-by turn up to 37 km (20 NM) prior to the turn waypoint, and fly a path displaced from that waypoint by as much as 16.7 km (9.0 NM). The defined radius for the Fixed Radius Transition (FRT) turn dictates how early the aircraft starts the turn and the displacement from the waypoint. Fly by and FRT turns, therefore, have the possibility of affecting a restricted area or another route on the inside of the turn. For instrument flight procedures, the Radius arc to a Fix (RF) path terminator will provide consistent turn performance (refer to Figures 5-1 and 5-2). Further details on this issue can be found in the Manual on the Use of Performance-based Navigation (PBN) in Airspace Design (Doc 9992).*

*Note 3.— An example of a prescribed lateral separation minima based on a specific navigation performance can be found in 5.4.1.2.1.6.*

---

*Editorial Note.— Delete existing Figures 5-1 and 5-2 and replace them with the following new figures.*

---

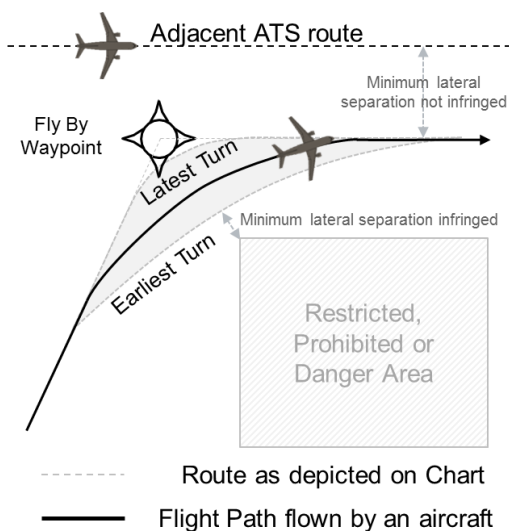

### Fly By Turns

Aircraft will calculate a turn radius and angle of bank (AOB) subject to performance characteristics, airspeed, altitude, angle of turn and wind conditions. Aircraft determine to initiate the turn, prior to the waypoint, based on the calculated radius – this may be up to 20 NM before the waypoint. There will be variation in the paths because each aircraft calculates its own turn radius (indicated by the grey area in the figure within which the flight path of the aircraft will be located). This variation becomes more apparent at higher altitudes and greater turn angles. The controller can expect the aircraft track to be on the inside of the waypoint.

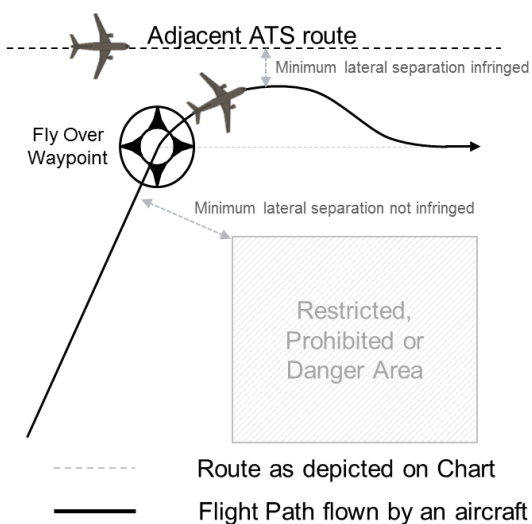

### Flyover Turns

Aircraft will come to the overhead of the waypoint before initiating the turn onto the next leg. Therefore, if the minimum prescribed lateral separation is applied, it will be infringed as the aircraft manoeuvres onto its next leg. The controller can expect the aircraft track to be on the outside of the waypoint.

**Figure 5-1. Turn over flyover waypoint and Turn at fly-by waypoint (See 5.4.1.1.4)**

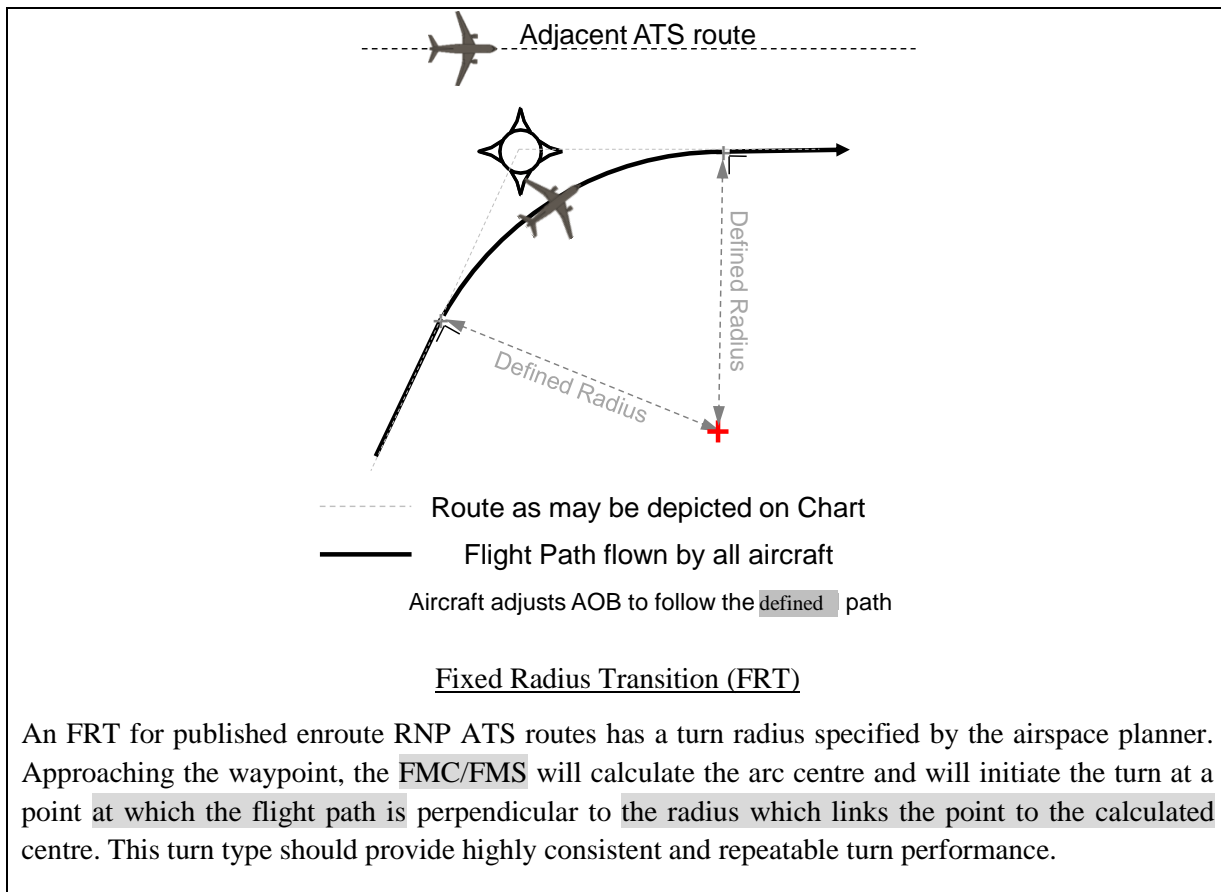

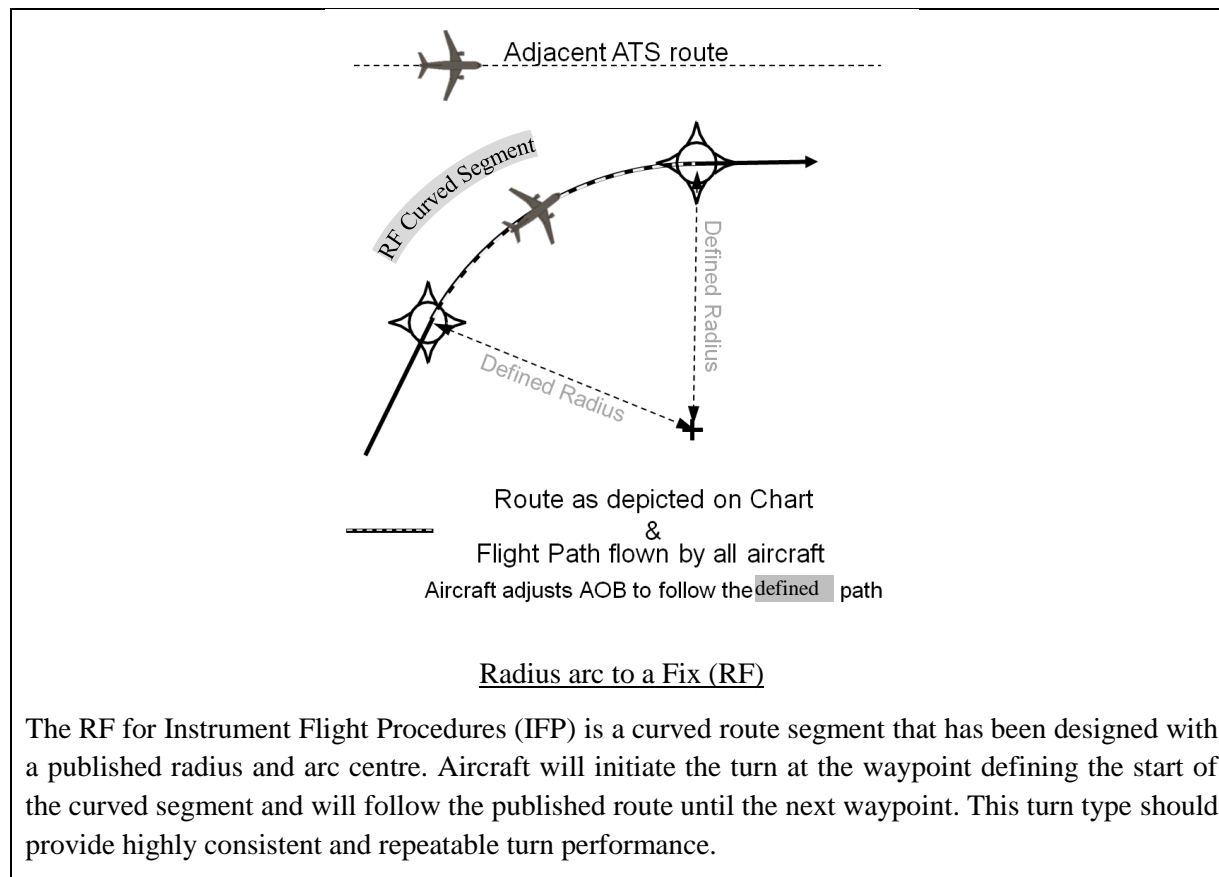

**Figure 5-2. Fixed Radius Transition (FRT) and Radius arc to a Fix (RF) Turn (See 5.4.1.1.4)**

...

---

*Editorial Note.*— Out of consistency, *amend* the existing term “fixed radius transition” in Note 2 of paragraph 5.4.1.2.1.2 to read as “Fixed Radius Transition (FRT)”

---

...

#### 5.4.1.2 LATERAL SEPARATION CRITERIA AND MINIMA

...

5.4.1.2.1.6 *Lateral separation of aircraft on parallel or non-intersecting tracks or ATS routes.* Within designated airspace or on designated routes, lateral separation between aircraft operating on parallel or non-intersecting tracks or ATS routes shall be established in accordance with Table 5-2:

---

*Editorial Note.*— *Relocate minima and requirements in existing strikethrough text in bullets a), b), c), d) and e) in the following new table (5-2). New text that is inserted with existing text is highlighted with grey shading and underlined*

---

- a) ~~for a minimum spacing between tracks of 93 km (50 NM) a navigational performance of RNAV 10 (RNP 10), RNP 4 or RNP 2 shall be prescribed;~~
- b) ~~for a minimum spacing between tracks of 42.6 km (23 NM) a navigational performance of RNP 4 or RNP 2 shall be prescribed. The communication system shall satisfy required~~

communication performance 240 (RCP 240) and the surveillance system shall satisfy required surveillance performance 180 (RSP 180). Conformance monitoring shall be ensured by establishing an ADS-C event contract specifying a lateral deviation change event with a maximum of 5 NM threshold and a waypoint change event;

- e) ~~for a minimum spacing between tracks of 27.8 km (15 NM) a navigational performance of RNP 2 or a GNSS equipage shall be prescribed. Direct controller pilot VHF voice communication shall be maintained while such separation is applied;~~
- d) ~~for a minimum spacing between tracks of 13 km (7 NM), applied while one aircraft climbs/descends through the level of another aircraft, a navigational performance of RNP 2 or a GNSS equipage shall be prescribed. Direct controller pilot VHF voice communication shall be maintained while such separation is applied; and~~
- e) ~~for a minimum spacing between tracks of 37 km (20 NM), applied while one aircraft climbs/descends through the level of another aircraft whilst using other types of communication than specified in d) above, a navigational performance of RNP 2 or a GNSS equipage shall be prescribed.~~

Insert new table as follows:

**Table 5-2. Lateral separation of aircraft on parallel or non-intersecting tracks or ATS routes**

Minimum Spacing Between Tracks		Performance Requirements			Additional Requirements
Airspace where SLOP is not authorized, or is only authorized up to 0.5 NM	Airspace where SLOP up to 2 NM is authorized	Navigation	Communication	Surveillance	
93 km (50 NM)	93 km (50 NM)	RNAV 10 (RNP 10) RNP 4 RNP 2	<u>Types of communication other than Direct controller-pilot VHF voice</u>		
<u>37 km (20 NM)</u>	42.6 km (23 NM)	RNP 4 RNP 2	RCP 240	RSP 180	Conformance monitoring shall be ensured by establishing an ADS-C event contract specifying a lateral deviation change event with a maximum of 5 NM threshold and a waypoint change event

Minimum Spacing Between Tracks		Performance Requirements			Additional Requirements
37 km (20 NM)	<del>42.6 km</del> <u>(23 NM)</u>	RNP 2 or GNSS Equipage	<u>Types of communication other than Direct controller-pilot VHF voice</u>		While one aircraft climbs/descends through the level of another aircraft <u>remaining in level flight</u>
27.8 km (15 NM)	<del>32.4 km</del> <u>(18 NM)</u> <u>N/A</u>	RNP 2 or GNSS Equipage	Direct controller-pilot VHF voice communication		
<u>16.7 km (9 NM)</u>	<del>21.6 km</del> <u>(12 NM)</u> <u>N/A</u>	<u>RNP 4</u> <u>RNP 2</u>	<u>RCP 240</u>	<u>RSP 180</u>	<u>While one aircraft climbs/descends through the level of another aircraft remaining in level flight</u>
13 km (7 NM)	<del>19 km</del> <u>(10 NM)</u> <u>N/A</u>	RNP 2 or GNSS Equipage	Direct controller-pilot VHF voice communication		While one aircraft climbs/descends through the level of another aircraft <u>remaining in level flight</u>

End of new table.

Note 1.— Guidance material for the implementation of the navigation capability supporting ~~93 km (50 NM), 42.6 km (23 NM), 37 km (20 NM), 27.8 km (15 NM) and 13 km (7 NM)~~ the lateral separation minima above is contained in the Performance-based Navigation (PBN) Manual (Doc 9613). ~~Guidance material for~~ Information regarding the implementation of the ~~93 km (50 NM), 42.6 km (23 NM), 37 km (20 NM), 27.8 km (15 NM) and 13 km (7 NM)~~ lateral separation minima above is contained in Circular ~~341349~~, Guidelines for the Implementation of Lateral Separation Minima.

Note 2.— Guidance material for implementation of communication and surveillance capability supporting ~~93 km (50 NM) and 42.6 km (23 NM)~~ the lateral separation minima above is contained in the Performance-based Communication and Surveillance (PBCS) Manual (Doc 9869) and the Global Operational Data Link (GOLD) Manual (Doc 10037).

Note 3.— See Appendix 2, ITEM 10: EQUIPMENT AND CAPABILITIES, in relation to the GNSS prescribed in ~~e), d) and e)~~ in Table 5-2 above.

Note 4.— Refer to 16.5 for further details regarding application of strategic lateral offset procedures (SLOP).

5.4.1.2.1.7 When the minima in 5.4.1.2.1.6 are applied by requiring one or both aircraft to establish a specified lateral offset, vertical separation shall be maintained by the controller until the manoeuvring aircraft is established on the applicable lateral offset.

---

*Editorial Note.*— *Renumber* subsequent paragraphs; and *change* the number of Circular 341 to 349 in the Note of existing paragraph 5.4.1.2.1.8.

---

## Chapter 6

### SEPARATION IN THE VICINITY OF AERODROMES

...

#### 6.7.2 Departing aircraft

...

##### 6.7.2.2 REQUIREMENTS AND PROCEDURES FOR INDEPENDENT PARALLEL DEPARTURES

Independent IFR departures may be conducted from parallel runways provided:

- a) the runway centre lines are spaced by ~~the a minimum~~ distance ~~of specified in~~ 760 m (2 500 ft) (see Annex 14, Volume I);
- b) the nominal departure tracks diverge by at least:
  - 1) 15 degrees immediately after take-off; or
  - 2) 10 degrees where
    - i) both aircraft are flying an RNAV or RNP instrument departure; and
    - ii) the turn commences no more than 3.7 km (2.0 NM) from the departure end of the runway;
- c) a suitable ATS surveillance ~~radar~~ system capable of identification of the aircraft within 21.9 km (1.0 NM) from the end of the runway is available; and
- d) ATS operational procedures ensure that the required track divergence is achieved.

*Note.*— *For further details refer to Circular 350, Guidelines for the Implementation of Reduced Divergence Departures.*

...

#### 6.7.3 Arriving aircraft

...

##### 6.7.3.2 REQUIREMENTS AND PROCEDURES FOR INDEPENDENT PARALLEL APPROACHES

6.7.3.2.1 Independent parallel approaches may be conducted to parallel runways provided that:

- a) the runway centre lines are spaced by the distance specified in Table 6-1 (see Annex 14, Volume I); and the surveillance criteria contained in Table 6-1 are met;



- 1) ~~where runway centre lines are spaced by less than 1 310 m but not less than 1 035 m, suitable secondary surveillance radar (SSR) equipment, with a minimum azimuth accuracy of 0.06 degrees (one sigma), an update period of 2.5 seconds or less and a high resolution display providing position prediction and deviation alert is available; or~~
- 2) ~~where runway centre lines are spaced by less than 1 525 m but not less than 1 310 m, SSR equipment with performance specifications other than the foregoing may be applied, provided they are equal to or better than those stated under 3) below, and when it is determined that the safety of aircraft operation would not be adversely affected; or~~
- 3) ~~where runway centre lines are spaced by 1 525 m or more, suitable surveillance radar with a minimum azimuth accuracy of 0.3 degrees (one sigma) or better and update period of 5 seconds or less is available;~~

~~For the above cases, other equivalent ATS surveillance systems (e.g. ADS-B or MLAT) may be used to provide the services detailed above provided that a performance capability equal to or better than that required for the above can be demonstrated.~~

**Table 6-1. ATS surveillance system criteria for different runway spacings**

Runway centre line spacing	ATS surveillance system criteria
Less than 1 310 m (4 300 ft) but not less than 1 035 m (3 400 ft)	<ul style="list-style-type: none"> <li>• a minimum accuracy for an ATS surveillance system as follows:               <ul style="list-style-type: none"> <li>○ for SSR, an azimuth accuracy of 0.06 degrees (one sigma); or</li> <li>○ for MLAT or ADS-B, an accuracy of 30 m (100 ft);</li> </ul> </li> <li>• an update period of 2.5 seconds or less, and</li> <li>• a high resolution display providing position prediction and deviation alert is available.</li> </ul>
Less than 1 525 m (5 000 ft) but not less than 1 310 m (4 300 ft)	<ul style="list-style-type: none"> <li>• an ATS surveillance system with performance specifications other than those above, but equal to or better than:               <ul style="list-style-type: none"> <li>○ for SSR a minimum azimuth accuracy of 0.3 degrees (one sigma); or</li> <li>○ for MLAT or ADS-B, a performance capability equivalent to or better than the SSR requirement can be demonstrated;</li> </ul> </li> <li>• an update period of 5 seconds or less, and</li> <li>• when it is determined that the safety of aircraft operations would not be adversely affected.</li> </ul>
1 525 m (5 000 ft) or more	<ul style="list-style-type: none"> <li>• a minimum SSR azimuth accuracy of 0.3 degrees (one sigma), or for MLAT or ADS-B, a performance capability equivalent to or better than the SSR requirement can be demonstrated; and</li> <li>• an update period of 5 seconds or less.</li> </ul>

*Note 1.— Guidance material Information pertaining to use of ADS-B and ~~multilateration (MLAT) systems~~—and their system performance is contained in the Assessment of ADS-B and Multilateration Surveillance to Support Air Traffic Services and Guidelines for Implementation (Circ 326).*

*Note 2.— Refer to Chapter 2, Section 2.6.2 f) on ADS-B implementation that envisages reliance upon a common source for surveillance and/or navigation.*

- b) the instrument approach procedures that align the aircraft with the extended runway centre line ~~used~~ are any combination of the following:
  - 1) a precision approach procedure; or
  - 2) except as provided in 6.7.3.2.1.b) 3), an approach with vertical guidance (APV) designed using the RNP AR APCH specification where:
    - i) the RNP value for B, and the RNP value for C, if that segment of the approach is within the horizontal separation minimum of a parallel approach, does not exceed one-quarter of the distance between runway centre lines (A), (Figure 6-1 refers); and
    - ii) the RNP value for B, and the RNP value for C, if that part of the approach is within the horizontal separation minimum of a parallel approach, does not exceed (A-D)/2, (Figure 6-1 refers); or
  - 3) an APV procedure designed using either the RNP APCH or RNP AR APCH navigation specification, provided that:
    - i) an appropriate, documented safety assessment has shown that an acceptable level of safety can be met;
    - ii) operations are approved by the appropriate ATS authority (Note 1. refers); and
    - iii) the instrument approach is demonstrated to protect the NTZ from infringement during normal operations.

*Note 1.— The demonstration of the safety of an APV procedure designed using either RNP APCH or RNP AR APCH navigation specification during simultaneous approaches may consider: the collision risk from normal and residual (not mitigated) atypical errors; likelihood of ACAS nuisance alerting during normal operations; wake hazard; monitoring and available levels of system automation; data base management; flight management system input and related crew workload; impacts of meteorological conditions and other environmental factors; training and published ATC break-out procedures.*

*Note 2. — For examples of the approach types and scenarios applicable to 6.7.3.2.1 b) see Manual on Simultaneous Operations on Parallel or Near-Parallel Instrument Runways (SOIR) (Doc 9643), Table 2-2 and Appendix C.*

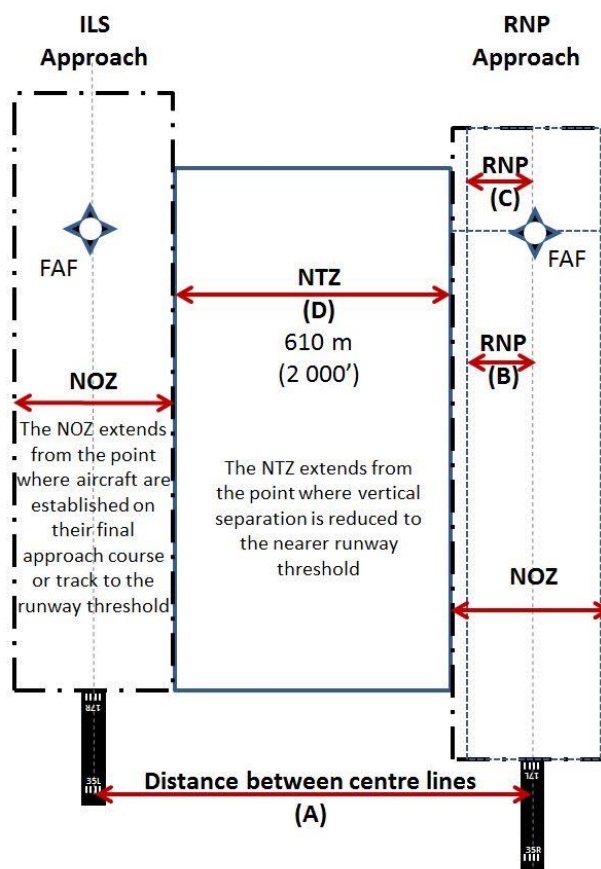

**Figure 6-1 Distance between centre lines, NTZ and NOZ.**

---

*Editorial Note.— Renumber subsequent figures.*

---

- b) instrument landing system (ILS) and/or microwave landing system (MLS), approaches, are being conducted on both runways;
- c) the nominal missed approach tracks for one approach of the missed approach procedures diverges by at least 30 degrees from the missed approach track of the adjacent approach;
- d) an obstacle survey and evaluation is completed, as appropriate, for the areas adjacent to the final approach segments;
- e) aircraft are advised as early as possible, of the assigned runway identification and the ILS localizer or MLS frequency as early as possible, instrument approach procedure and any additional information considered necessary to confirm correct selection;
- f) vectoring is used to intercept the final approach course or track ILS localizer course, or the MLS final approach track, is intercepted by use of:
  - 1) vectoring; or
  - 2) a published arrival and approach procedure that intercepts with the IAF or IF;

- g) a no transgression zone (NTZ) at least 610 m (2 000 ft) wide is established equidistant between extended runway centre lines and is depicted on the ATS surveillance system situation display;
- h) the approaches are monitored by:
  - 1) a separate monitoring controller for each runway; or
  - 2) a single monitoring controller for no more than two runways, if determined by a safety assessment and approved by the appropriate ATS authority (6.7.3.2.2 refers);
- hi) ~~separate controllers monitor the approaches monitoring to each runway and ensure~~ that when the 300 m (1 000 ft) vertical separation is reduced:
  - 1) aircraft do not penetrate the depicted NTZ; and
  - 2) the applicable minimum longitudinal separation between aircraft on the same ~~I LS localizer course, or MLS final approach track~~ final approach course or track, is maintained; and
- ij) if no dedicated radio channels are available for the controllers to control the aircraft until landing:
  - 1) transfer of communication of aircraft to the respective aerodrome controller's channel is effected before ~~the higher~~ either of the two aircraft on adjacent final approach tracks intercepts the ~~I LS glide path or the specified MLS elevation angle~~ or vertical path for the selected instrument approach procedure; and
  - 2) the controller(s) monitoring the approaches to each runway are provided with the capability to override transmissions of aerodrome control on the respective radio channels for each arrival flow.

6.7.3.2.2 States conducting safety assessments to enable the monitoring of not more than two runways by a single controller (6.7.3.2.1.h refers) should review factors such as, but not limited to: complexity, times of operation, traffic mix and density, arrival rate, available levels of system automation, availability of back-up systems, impacts of meteorological conditions and other environmental factors.

6.7.3.2.23 As early as practicable after an aircraft has established communication with approach control, the aircraft shall be advised that independent parallel approaches are in force. This information may be provided through the ATIS broadcasts.

6.7.3.2.34 When vectoring to intercept the ~~I LS localizer course, or MLS final approach track~~, final approach course or track, the final vector shall meet the following conditions:

- a) enable the aircraft to intercept ~~the I LS localizer course or MLS final approach track~~ at an angle not greater than 30 degrees;
- b) ~~to~~ provide at least ~~2-1.9~~ 1.9 km (1.0 NM) straight and level flight prior to the ~~I LS localizer final approach course or MLS final approach track~~ intercept; and
- c) ~~The vector shall also~~ enable the aircraft to be established on the ~~I LS localizer course, or MLS final approach track~~ final approach course or track, in level flight for at least 3.7 km (2.0 NM) prior to intercepting the ~~I LS glide path or specified MLS elevation angle~~ or vertical path for the selected instrument approach procedure.

6.7.3.2.45 A minimum of 300 m (1 000 ft) vertical separation or, subject to radar-ATS surveillance system and situation display capabilities, a minimum of 5.6 km (3.0 NM) radar horizontal separation shall be provided until aircraft are established:

- a) inbound on the ~~ILS localizer course and/or MLS final approach track~~ final approach course or track; ~~or~~
- b) on an RNP AR APCH approach in accordance with 6.7.3.5; and
- c) within the normal operating zone (NOZ).

6.7.3.2.5,6 Subject to radar-ATS surveillance system and situation display capabilities, a minimum of 5.6 km (3.0 NM) radar horizontal separation, or 4.6 km (2.5 NM) as prescribed by the appropriate ATS authority, shall be provided between aircraft on the same ~~ILS localizer course, or MLS final approach track,~~ final approach course or track unless increased longitudinal separation is required due to wake turbulence or for other reasons.

*Note 1.— See Chapter 8, 8.7.3.2 and 8.7.3.4.*

*Note 2.— An aircraft established on ~~an~~ ~~ILS localizer~~ the final approach course, or ~~MLS final approach track~~ is separated from another aircraft established on an adjacent parallel ~~ILS localizer course, or MLS final approach track~~ final approach course or track provided neither aircraft penetrates the NTZ as depicted on the situation display.*

6.7.3.2.67 When assigning the final heading to intercept the ~~ILS localizer course, or MLS final approach track~~ final approach course or track, the runway shall be confirmed, and the aircraft shall be advised of:

- a) its position relative to a fix on the ~~ILS localizer course, or MLS final approach track~~ final approach course or track;
- b) the altitude to be maintained until established on the ~~ILS localizer course, or MLS final approach track~~ final approach course or track, to the ~~ILS glide path or specified MLS elevation angle or vertical path~~ intercept point; and
- c) if required, clearance for the appropriate ~~ILS, or MLS~~ approach.

6.7.3.2.78 All approaches regardless of meteorological conditions shall be provided with flight path monitoring using an ~~ATS surveillance radar system~~. Control instructions and information necessary to ensure separation between aircraft and to ensure aircraft do not enter the NTZ shall be issued.

*Note 1.— The primary responsibility for navigation on the ~~ILS localizer course and/or MLS final approach track~~ final approach course or track rests with the pilot. Control instructions and information are therefore issued only to ensure separation between aircraft and to ensure that aircraft do not penetrate the NTZ.*

*Note 2.— For the purpose of ensuring an aircraft does not penetrate the NTZ, the aircraft is considered to be the centre of its position symbol. However, the edges of the position symbols representing aircraft executing parallel approaches are not allowed to touch (see Chapter 8, 8.7.2).*

6.7.3.2.89 When an aircraft is observed to overshoot the turn-on or to continue on a track which will penetrate the NTZ, the aircraft shall be instructed to return immediately to the correct track.

6.7.3.2.910 When an aircraft is observed penetrating the NTZ, the aircraft on the adjacent ~~ILS localizer course, or MLS final approach track,~~ final approach course or track shall be instructed to immediately climb and turn to the assigned altitude/height and heading (break-out procedures) in order to avoid the deviating aircraft. Where parallel approach obstacle assessment surfaces (PAOAS) criteria are applied for the obstacle assessment, the ~~monitoring air traffic~~ controller shall not issue the heading instruction to the aircraft below 120 m (400 ft) above the runway threshold elevation, and the heading instruction shall not exceed 45 degrees track difference with the ~~ILS localizer course, MLS final approach track,~~ final approach course or track.

6.7.3.2.101 Flight path monitoring using an ~~ATS surveillance system radar~~ shall not be terminated until:

- a) visual separation is applied, provided procedures ensure that both controllers are advised whenever visual separation is applied;
- b) the aircraft has landed, or in case of a missed approach, is at least  $\geq$  1.9 km (1.0 NM) beyond the departure end of the runway and adequate separation with any other traffic is established.

*Note.— There is no requirement to advise the aircraft that flight path monitoring ~~using radar~~ is terminated.*

#### 6.7.3.3 SUSPENSION OF INDEPENDENT PARALLEL APPROACHES TO CLOSELY-SPACED PARALLEL RUNWAYS

Independent parallel approaches to parallel runways spaced by less than 1 525 m between their centre lines shall be suspended under certain meteorological conditions, as prescribed by the appropriate ATS authority, including wind shear, turbulence, downdrafts, crosswind and significant meteorological conditions such as thunderstorms, which might otherwise increase ~~ILS localizer course, and/or MLS final approach track~~ deviations from the final approach course or track to the extent that safety may be impaired.

*Note 1.— The increase in final approach track deviations would additionally result in an unacceptable level of deviation alerts being generated.*

*Note 2.— Guidance material relating to meteorological conditions is contained in the Manual on Simultaneous Operations on Parallel or Near-Parallel Instrument Runways (SOIR) (Doc 9643).*

#### 6.7.3.4 REQUIREMENTS AND PROCEDURES FOR DEPENDENT PARALLEL APPROACHES

6.7.3.4.1 Dependent parallel approaches may be conducted to parallel runways provided:

- a) the runway centre lines are spaced by ~~the distance specified in~~ 915 m (3 000 ft) or more (see Annex 14, Volume I);
- b) ~~the aircraft are vectored to intercept the final approach track;~~ the final approach course or track is intercepted by use of:
  - 1) vectoring; or
  - 2) a published arrival and approach procedure that intercepts with the IAF or IF;
- c) an ~~suitable~~ ~~ATS surveillance radar~~ ~~system~~ with a minimum ~~SSR~~ azimuth accuracy of

0.3 degrees (one sigma), or for MLAT or ADS-B a performance capability equivalent to or better than the SSR requirement can be demonstrated and update period of 5 seconds or less is available;

- d) ~~HLS and/or MLS approaches are being conducted on both runways;~~ the instrument flight procedures that align the aircraft with the extended runway centre line ~~used to the parallel runways~~ are any combination of the following:
- 1) a precision approach procedure;
  - 2) an APV procedure designed using the RNP AR APCH navigation specification, provided that the RNP value for B, and the RNP value for C if that segment of the approach is within the horizontal separation minimum of a parallel approach, does not exceed one-quarter of the distance between runway centre lines (A) (Figure 6-2 refers); and
  - 3) an APV procedure designed using the RNP AR APCH navigation specification that does not meet the provisions in d) 2) or an RNP APCH, provided that:
    - i) an appropriate, documented safety assessment has shown that an acceptable level of safety can be met; and
    - ii) operations are approved by the appropriate ATS authority (Note 1. refers).

*Note 1.— The demonstration of the safety of an APV procedure designed using either RNP APCH or RNP AR APCH navigation specification during simultaneous approaches may consider: the collision risk from normal and residual (not mitigated) atypical errors; likelihood of ACAS nuisance alerting during normal operations; wake hazard; monitoring and available levels of system automation; data base management; flight management system input and related crew workload; impacts of meteorological conditions and other environmental factors; training; and published ATC break-out procedures.*

*Note 2.— For examples of approach types and scenarios that meet the requirements of 6.7.3.4.1 d), see Manual on Simultaneous Operations on Parallel or Near-Parallel Instrument Runways (SOIR) (Doc 9643) Table 2-3 and Appendix C.*

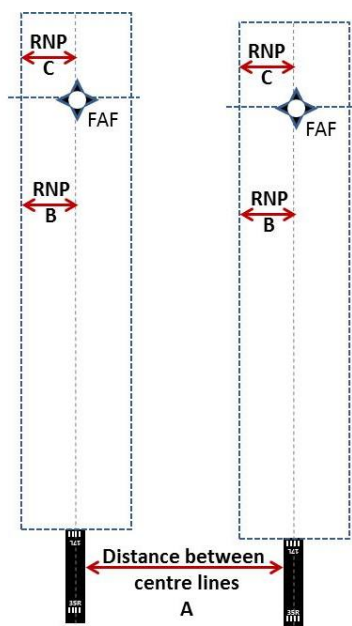

**Figure 6-2 — RNP value and distance between centre lines**

- e) aircraft are advised that approaches are in use to both runways (this information may be provided through the ATIS);
- f) the missed approach nominal tracks for one approach of the missed approach procedures diverges by at least 30 degrees; and
- g) approach control has a frequency override capability to aerodrome control.

6.7.3.4.2 A minimum of 300 m (1 000 ft) vertical separation or a minimum of 5.6 km (3.0 NM) ~~radar~~ horizontal separation shall be provided between aircraft until established on ~~during turn-on to the~~ final approach courses or tracks of parallel-ILS localizer courses, and/or MLS final approach tracks approaches.

6.7.3.4.3 The minimum ~~radar~~ horizontal separation to be provided between aircraft established on the same final approach course or track ~~ILS localizer course and/or MLS final approach track~~ shall be 5.6 km (3.0 NM) or 4.6 km (2.5 NM) as prescribed by the appropriate ATS authority, unless increased longitudinal separation is required due to wake turbulence.

*Note.*— See Chapter 8, 8.7.3.2 and 8.7.3.4

- a) ~~5.6 km (3.0 NM) between aircraft on the same ILS localizer course, or MLS final approach track unless increased longitudinal separation is required due to wake turbulence; and~~
- b) ~~3.7 km (2.0 NM) between successive aircraft on adjacent ILS localizer courses, or MLS final approach tracks (see Figure 2-3)~~

6.7.3.4.4 The minimum horizontal separation to be provided diagonally between successive aircraft on adjacent final approach courses or tracks shall be:

- a) 3.7 km (2.0 NM) between successive aircraft on adjacent final approach courses or tracks more than 2 529 m (8 300 ft) apart (Figure 6-3); or
- b) 2.8 km (1.5 NM) between successive aircraft on adjacent final approach courses or tracks more than 1 097 m (3 600 ft) but not more than 2 529 m (8 300 ft) apart. (Figure 6-4); or
- c) 1.9 km (1.0 NM) between successive aircraft on adjacent final approach courses or tracks more than 915 m (3 000 ft) but not more than 1 097 m (3 600 ft) apart. (Figure 6-5).



Insert new figures as follows:

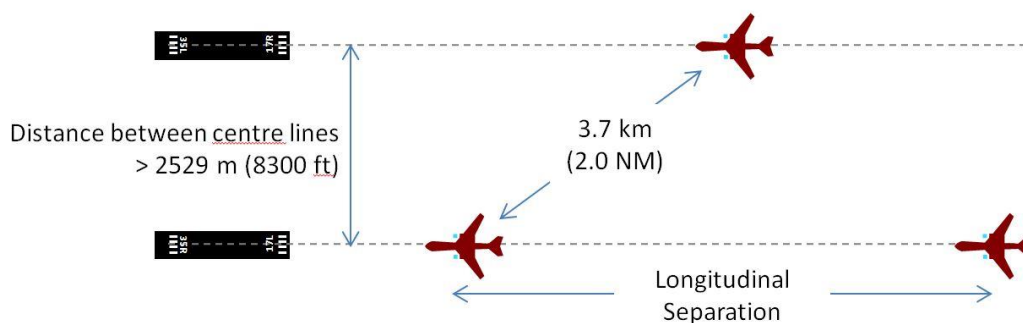

**Figure 6-3. Diagonal separation for distance between centre lines greater than 2 529m (8 300 ft)**

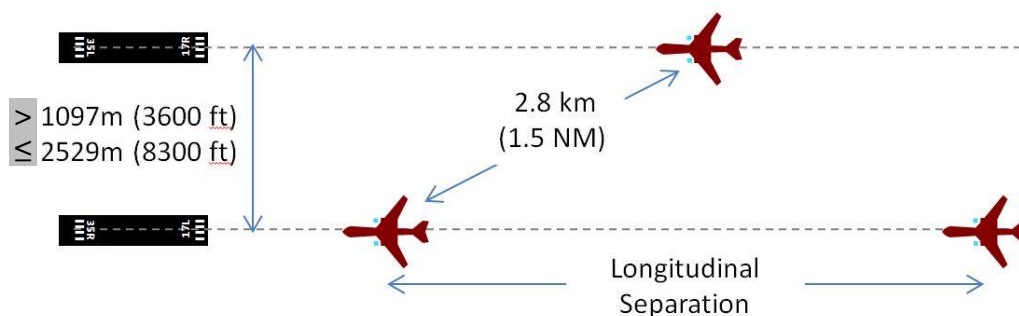

**Figure 6-4. Diagonal separation for distance between centre lines greater than 1 097 m (3 600 ft) but less than or equal to 2 529 m (8 300 ft)**

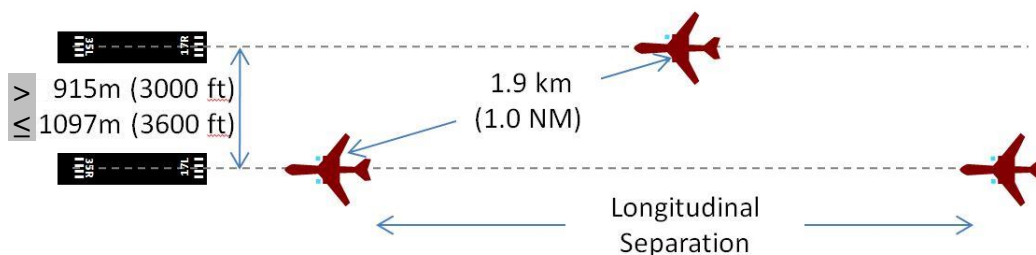

**Figure 6-5. Diagonal separation for distance between centre lines greater than 915 m (3 000 ft) but less than or equal to 1 097 m (3 600 ft)**

*Note.— Further detail is provided in appendices E and F to The Manual on Simultaneous Operations on Parallel or Near-Parallel Instrument Runways (Doc 9643) regarding the rationale and demonstration of safety of reduced diagonal separations.*

---

---

End of new figures.

---

---

*Insert new text as follows:*

---

---

### 6.7.3.5 DETERMINATION THAT AN AIRCRAFT IS ESTABLISHED ON RNP AR APCH

6.7.3.5.1 In addition to the requirements specified under 6.7.3.2, for the purposes of applying 6.7.3.2.5 b), an aircraft conducting an RNP AR APCH procedure is considered to be established for the entire approach procedure after the IAF/IF provided that:

- a) the aircraft confirms that it is established on the RNP AR APCH procedure prior to a designated point, the location of such point to be determined by the appropriate ATS authority;
- b) the designated point shall be positioned on the RNP AR APCH to ensure the applicable horizontal separation minimum (e.g. 5.6 km (3 NM)) from the adjacent approach procedure (Figure 6-6 refers). The designated point may normally be coincident with the IAF; and
- c) to facilitate the application of the procedure, the designated point shall be readily apparent to the approach and monitoring controllers. The designated point may be depicted on the situation display.

6.7.3.5.2 Appropriate wake turbulence separation shall be applied between aircraft on the same approach.

6.7.3.5.3 If, after reporting that it is established on the RNP AR APCH procedure, the aircraft is unable to execute the procedure, the pilot shall notify the controller immediately with a proposed course of action, and thereafter follow ATC instructions (e.g. break-out procedure).

*Note.— Break-out procedures are described in Manual on Simultaneous Operations on Parallel or Near-Parallel Instrument Runways (SOIR) (Doc 9643).*

6.7.3.5.4 In circumstances where a break-out procedure becomes necessary during the application of the independent parallel approach procedure (for example, an aircraft penetrating the NTZ), the controller may issue climb and/or heading instructions to an aircraft established on an RNP AR APCH.

6.7.3.5.5 To support a break-out instruction, an obstacle assessment shall be completed.

*Note: — Guidance on obstacle assessment is provided in the Manual on Simultaneous Operations on Parallel or Near-Parallel Instrument Runways (SOIR) (Doc 9643).*

6.7.3.5.6 Break-out procedures shall be prescribed in the AIP and local instructions.

6.7.3.5.7 The monitoring controller shall protect the NTZ, in accordance with 6.7.3.2.1 i).

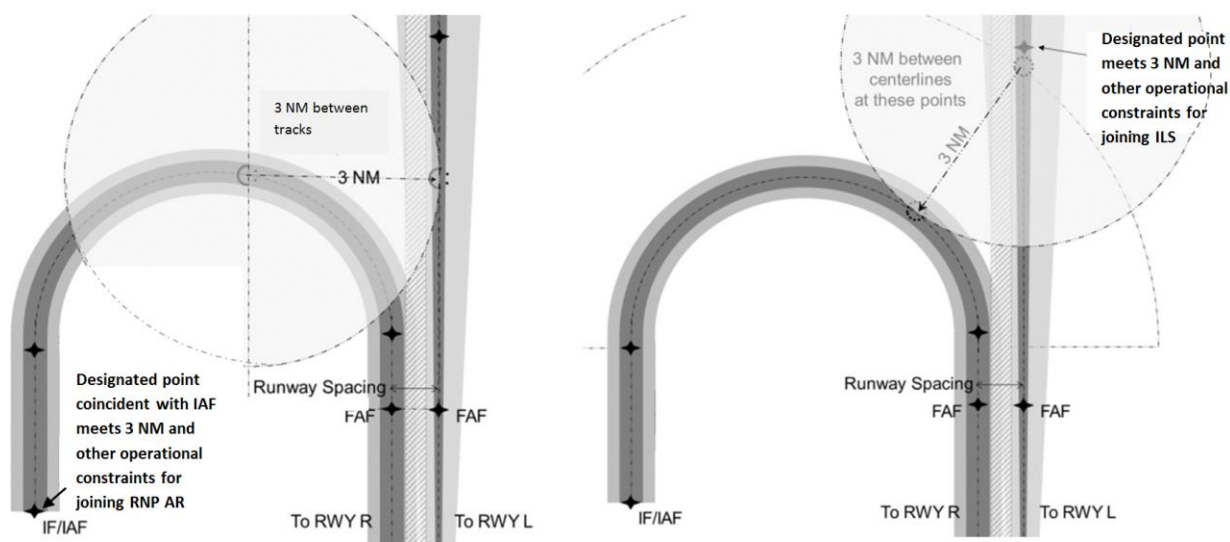

**Figure 6-6. 'Established on RNP AR APCH' Concept  
(RNP AR APCH/Precision approach with 3 NM Separation minimum example)**

---

End of new text.

---

### 6.7.3.56 REQUIREMENTS AND PROCEDURES FOR SEGREGATED PARALLEL OPERATIONS

6.7.3.56.1 Segregated parallel operations may be conducted on parallel runways provided:

- the runway centre lines are spaced by ~~the distance specified in~~ a minimum of 760 m (2 500 ft) (see Annex 14, Volume I); and
- the nominal departure track diverges immediately after take-off by at least 30 degrees from the missed approach track of the adjacent approach (see Figure 6-17).

6.7.3.56.2 The minimum distance between parallel runway centre lines for segregated parallel operations may be decreased by 30 m for each 150 m that the arrival runway is staggered toward the arriving aircraft, to a minimum of 300 m (see Figure 6-28) and should be increased by 30 m for each 150 m that the arrival runway is staggered away from the arriving aircraft (see Figure 6-39).

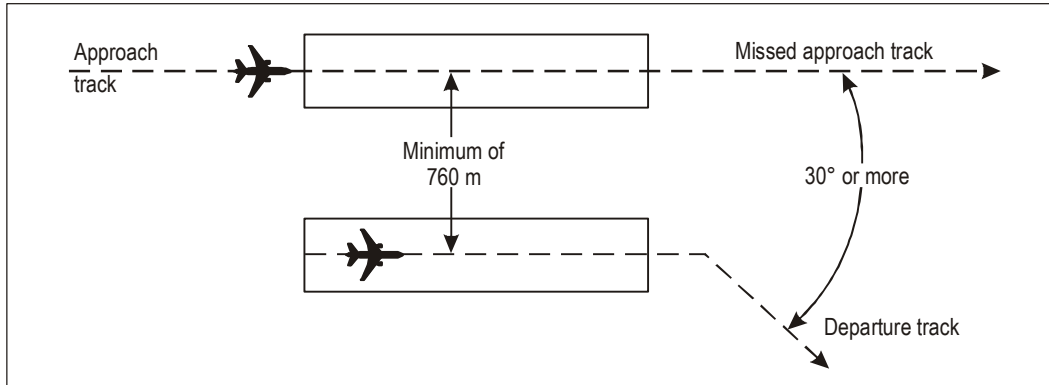

**Figure 6-17. Segregated parallel operations (see 6.7.3.56.1 b))**

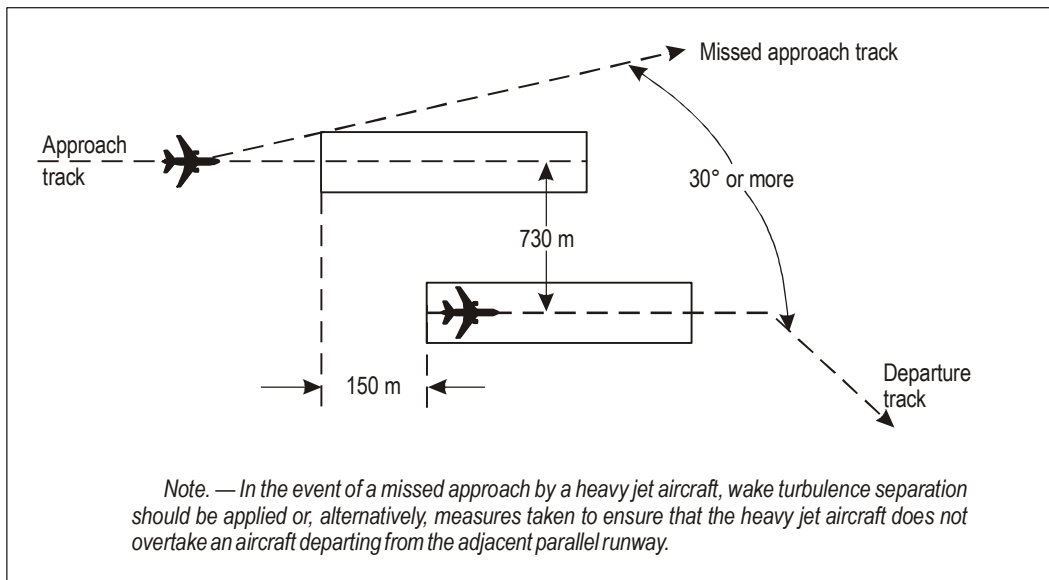

**Figure 6-28. Segregated parallel operations where runways are staggered (see 6.7.3.56.2)**

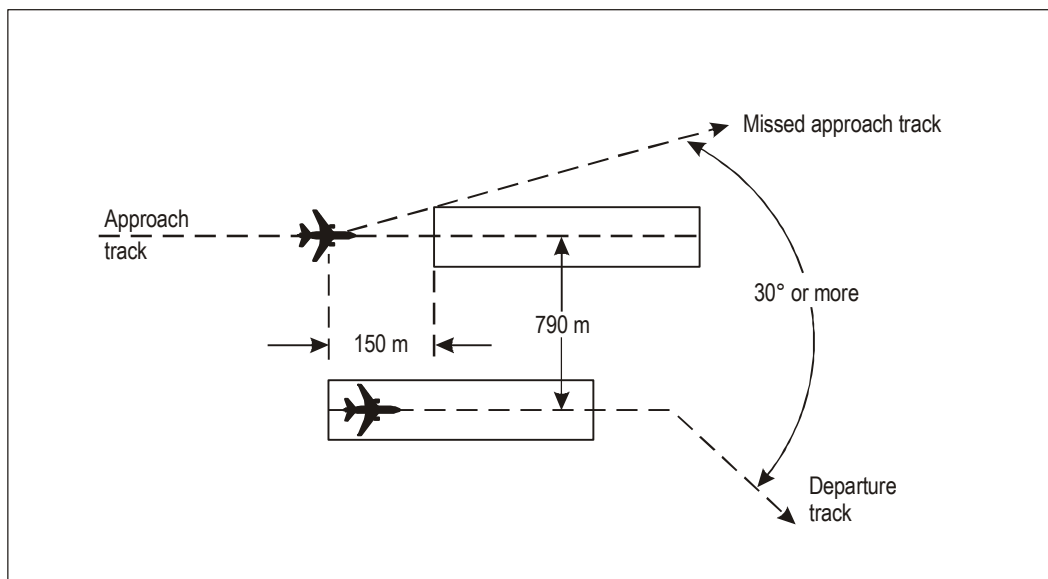

**Figure 6-39. Segregated parallel operations where runways are staggered (see 6.7.3.56.2)**

6.7.3.56.3 The following types of approach procedures may be conducted—utilized in segregated parallel operations provided a suitable radar-ATS surveillance system and the appropriate ground facilities conform to the standard necessary for the specific type of approach:

- ILS and/or MLS precision approaches and/or APV (RNP AR APCH, RNP APCH);
- surveillance radar approach (SRA) or precision approach radar (PAR) approach; and
- visual approach.

*Note.*— Guidance material is contained in the Manual on Simultaneous Operations on Parallel or Near-Parallel Instrument Runways (SOIR) (Doc 9643).

**Source B**

...

## Chapter 7

### PROCEDURES FOR AERODROME CONTROL SERVICE

...

#### 7.1 FUNCTIONS OF AERODROME CONTROL TOWERS

## 7.1.1 General

...

7.1.1.2 Aerodrome controllers shall maintain a continuous watch on all flight operations on and in the vicinity of an aerodrome as well as vehicles and personnel on the manoeuvring area. Watch shall be maintained by visual observation, augmented ~~in low visibility conditions~~ when available by an ATS surveillance system ~~when available~~. Traffic shall be controlled in accordance with the procedures set forth herein and all applicable traffic rules specified by the appropriate ATS authority. If there are other aerodromes within a control zone, traffic at all aerodromes within such a zone shall be coordinated so that traffic circuits do not conflict.

*Note.— Provisions for the use of an ATS surveillance system in the aerodrome control service are contained in Chapter 8, Section 8.10.*

7.1.1.2.1 Visual observation shall be achieved through direct out-of-the-window observation, or through indirect observation utilizing a visual surveillance system which is specifically approved for the purpose by the appropriate ATS authority.

*Note 1.— For the purposes of automatic recording of visual surveillance system data, Annex 11, 6.4.1 applies.*

*Note 2.— Guidance material on the implementation of the remote tower concept for single mode of operation can be found in the Annex to European Aviation Safety Agency (EASA) Executive Director Decision 2015/014/R (3 July 2015).*

## 7.6 CONTROL OF AERODROME TRAFFIC

...

### 7.6.3 Traffic on the manoeuvring area

#### 7.6.3.1 CONTROL OF TAXIING AIRCRAFT

...

7.6.3.1.3.2 Aircraft shall not be permitted to line up and hold on the approach end of a runway-in-use whenever another aircraft is effecting a landing, until the landing aircraft has passed the point of intended holding.

*Note.— See Figure 7-2*

...

~~Figure 7-2. Method of holding aircraft (see 7.6.3.1.3.2)~~

...

---

*Insert new text as follows:*

---

## 7.12 USE OF A VISUAL SURVEILLANCE SYSTEM IN AERODROME CONTROL SERVICE

### 7.12.1 Capabilities

7.12.1.1 Visual surveillance systems used in the provision of aerodrome control services shall have an appropriate level of reliability, availability and integrity. The possibility of system failures or significant system degradations which may cause complete or partial interruptions of service shall be assessed and taken into account in the definition of the level of service provided in order to ensure that there is no degradation in the safety level of the services rendered. Backup facilities or alternative operational procedures shall be provided.

*Note.— A visual surveillance system will normally consist of a number of integrated elements, including sensor(s), data transmission links, data processing systems and situation displays.*

7.12.1.2 Visual surveillance systems should have the capability to receive, process and display, in an integrated manner, data from all connected resources.

## **7.12.2 Functions**

7.12.2.1 When approved by and subject to conditions prescribed by the appropriate ATS authority, visual surveillance systems may be used in the provision of aerodrome control service to perform the functions listed in 7.1.

7.12.2.2 The level of service to be provided shall be commensurate with the technical capabilities of the system.

---

End of new text.

---



---

*Editorial Note.— Renumber the following sections accordingly.*

---

## **7.123 PROCEDURES FOR LOW VISIBILITY OPERATIONS**

...

### **Chapter 8**

#### **ATS SURVEILLANCE SERVICES**

...

8.1.12 The provision of ATS surveillance services shall be limited to specified areas of coverage and shall be subject to such other limitations as have been specified by the appropriate ATS authority. Adequate information on the operating methods used shall be published in aeronautical information publications, as well as operating practices and/or equipment limitations having direct effects on the operation of the air traffic services.

*Note.— States will provide information on the area or areas where PSR, SSR, ADS-B and MLAT systems are in use as well as ATS surveillance services and procedures in accordance with Annex 15, 4.1.1 and PANS-AIM, Appendix 13.*

## 8.6 GENERAL PROCEDURES

...

### 8.6.5 Vectoring

8.6.5.1 Vectoring shall be achieved by issuing to the pilot specific headings which will enable the aircraft to maintain the desired track. When vectoring an aircraft, a controller shall comply with the following:

...

- b) when an aircraft is given its initial vector diverting it from a previously assigned route, the pilot ~~shall~~ should be informed what the vector is to accomplish, and the limit of the vector ~~shall~~ should be specified when the assigned heading is such that a loss of communications may result in a safety risk (e.g. to ... position, for ... approach);

*Note.— Annex 19 — Safety Management defines a safety risk as the predicted probability and severity of the consequences or outcomes of a hazard.*

...

## CHAPTER 9

### FLIGHT INFORMATION SERVICE AND ALERTING SERVICE

#### 9.1 FLIGHT INFORMATION SERVICE

...

##### 9.1.3 Transmission of information

...

##### 9.1.3.8 TRANSMISSION OF INFORMATION CONCERNING SPACE WEATHER ACTIVITY

Information on space weather phenomena that have an impact on high frequency radio communications, communications via satellite, GNSS-based navigation and surveillance systems, and/or pose a radiation risk to aircraft occupants at flight levels, within the area of responsibility of the ATS unit shall be transmitted to the affected aircraft by one or more of the means specified in 9.1.3.1.1.

...

## Chapter 11



## AIR TRAFFIC SERVICES MESSAGES

...

### 11.4 MESSAGE TYPES AND THEIR APPLICATION

...

#### 11.4.2 Movement and control messages

...

##### 11.4.2.6 CONTROL MESSAGES

...

##### 11.4.2.6.3 FLOW CONTROL MESSAGES

*Note 1.— Provisions governing the control of air traffic flow are set forth in Annex 11, 3.7.5 and in Chapter 3, 3.2.5.2 of this document. Attention is drawn, however, to the guidance material contained in the ~~Air Traffic Services Planning Manual (Doc 9426) regarding flow control.~~ Manual on Collaborative Air Traffic Flow Management (Doc 9971).*

...

## Chapter 12

### PHRASEOLOGIES

#### 12.1 COMMUNICATIONS PROCEDURES

...

#### 12.2 GENERAL

...

12.2.6 Phraseologies for the movement of vehicles, ~~other than tow tractors~~, on the manoeuvring area shall be the same as those used for the movement of aircraft, with the exception of taxi instructions, in which case the word “PROCEED” shall be substituted for the word “TAXI” when communicating with vehicles.

...

## CHAPTER 15

### PROCEDURES RELATED TO EMERGENCIES, COMMUNICATION FAILURE AND CONTINGENCIES

...

#### 15.5 OTHER IN-FLIGHT CONTINGENCIES

...

### 15.5.5 Descents by ~~supersonic~~ aircraft due to solar ~~cosmic~~ radiation from space weather events

Air traffic control units should be prepared for the possibility that ~~supersonic~~ aircraft ~~operating at levels above 15 000 m (49 000 ft)~~ may, on rare occasions, experience a rise in solar ~~cosmic~~ radiation which requires them to descend to lower levels, ~~possibly down to or below the levels being used by subsonic aircraft~~. When such a situation is known or suspected, air traffic control units should take all possible action to safeguard all aircraft concerned, including any ~~subsonic~~ aircraft affected by the descent.

*Note.— All ~~supersonic~~ aircraft in a particular portion of airspace and above a certain altitude may will be affected at the same time, and the event may be accompanied by a deterioration or loss of air-ground communications. It is expected that the aircraft will alert air traffic control units before the radiation reaches a critical level and will request a descent clearance when the critical level is reached. However, situations may occur in which the aircraft will need to descend without waiting for a clearance. In such cases, the aircraft are expected to advise air traffic control units, as soon as possible, of the emergency action taken.*

— END —